



High Voltage Fuse / SL-632GF 高压保险管

For Microwave Oven
适用于微波炉

Quick-Acting(F)

1. Standard(标准)

IEC-60127-2/IV

2. Materials(物料)

Fuse body: Glass tube

End cap: Nickel-plated brass

Spring: Ag plated brass

3. Operating Temperature(工作温度)

-25 °C to +85 °C (consider de-rating)

4. Stock Conditions(贮存条件)

+10°C to +60°C

**relative humidity \leq 75% yearly average,
without dew, maximum value for 30days-95%.**



SELLI

WWW.SELLIFUSE.COM

5. Vibration Resistance(振蕩承載能力)

24 cycles at 15 min. each (EN 60068-6)

10-60Hz at 0.75mm amplitude

60-2000Hz at 10g acceleration

6. Solderability(可焊性)

260°C, ≤3 sec.(Wave)

350°C, ≤1 sec.(Hand)

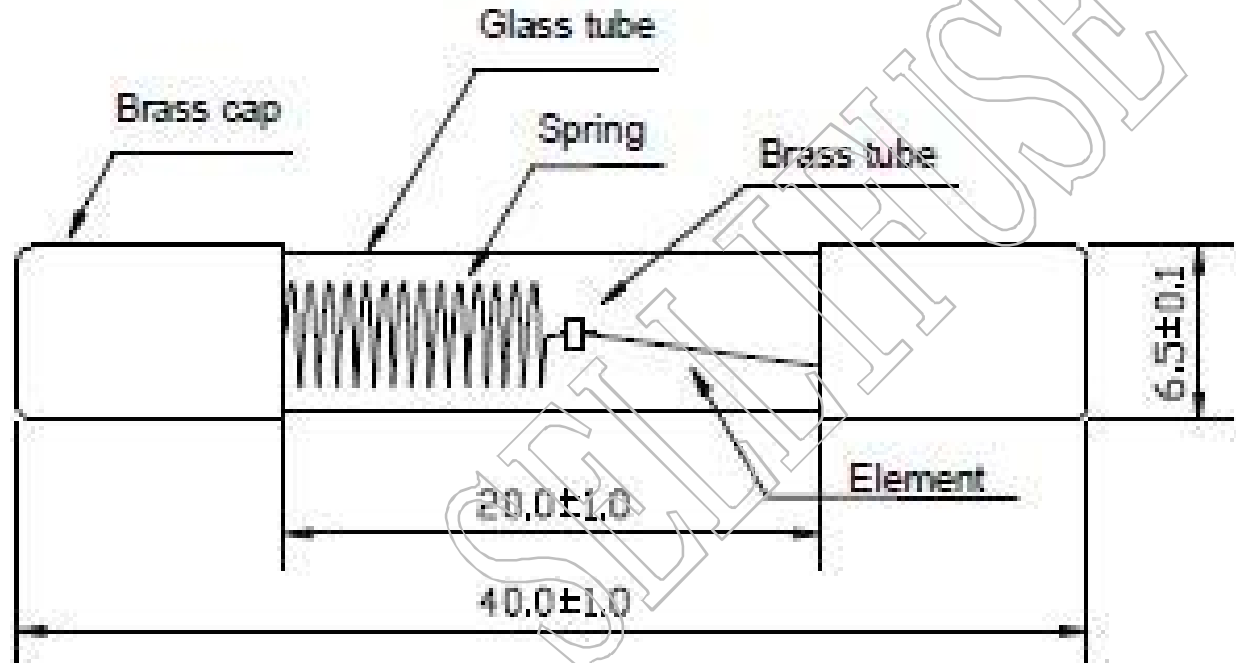

Dimension (mm)



SELLI

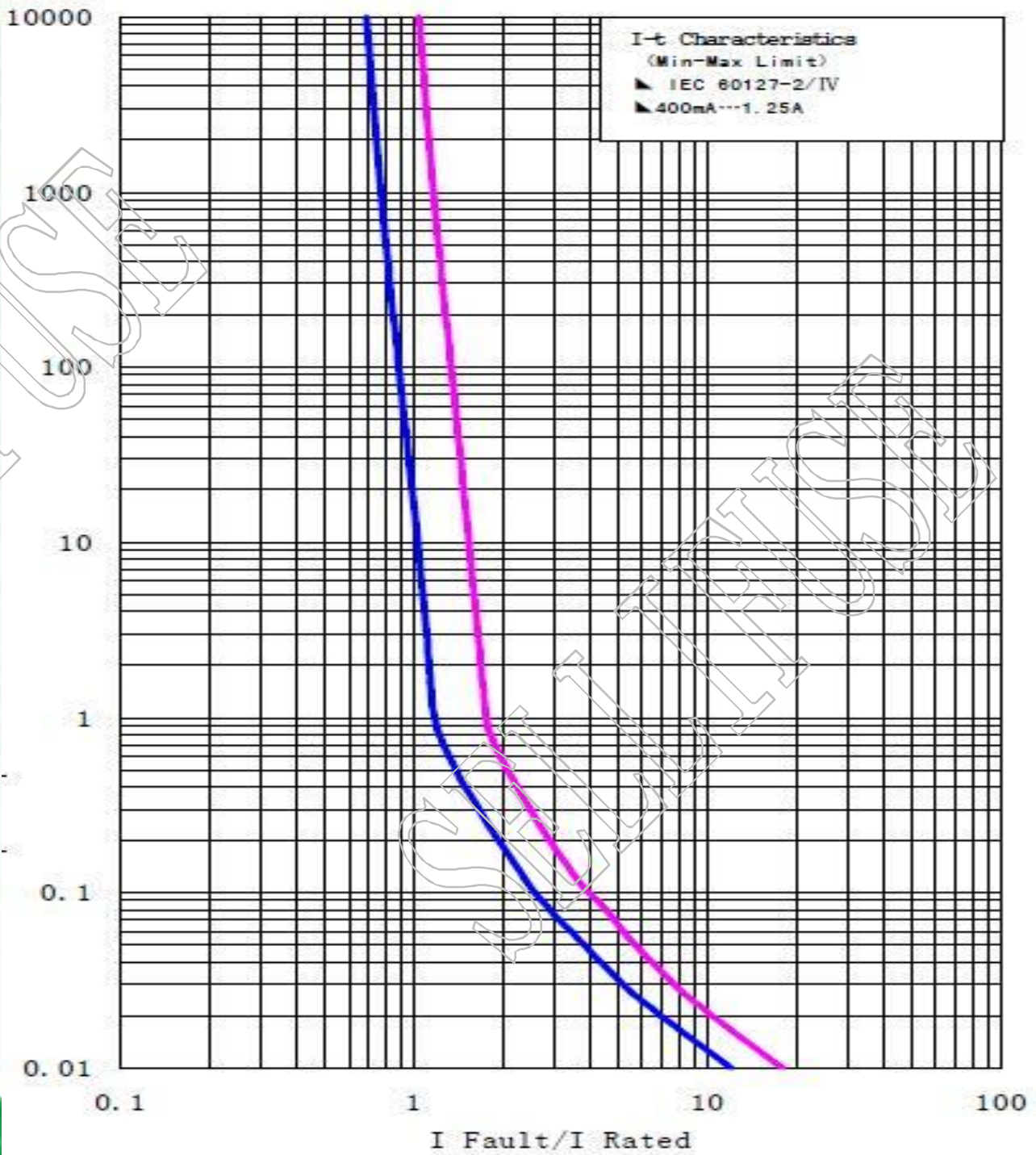
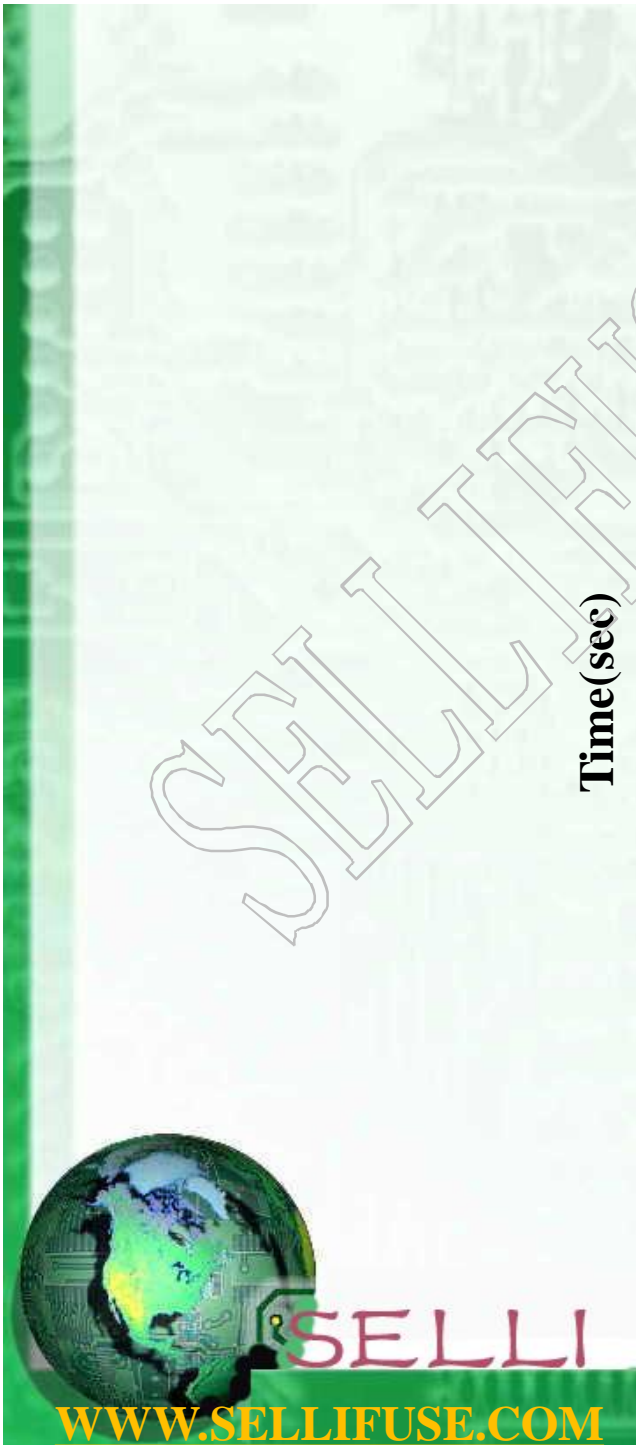

Electrical Characteristics: IEC-60127-2/IV

Rated Current	115%	150%	200%	275%	400%	1000%
400mA~1.25A	>4h	<300s	<20s	20ms~1500ms	8ms~400ms	<80ms



Permissible continuous operating current is $\leq 100\%$ at ambient temperature of 23°C (73.4°F).

Rated Current	Amp Code	Voltage Rating	Voltage Drop(mv)MAX	Approvals
				TUV
400mA	0400	5KV	1000	○
500mA	0500	5KV	1000	○
600mA	0600	5KV	1000	●
650mA	0650	5KV	1000	●
700mA	0700	5KV	1000	●
750mA	0750	5KV	1000	●
800mA	0800	5KV	1000	●
850mA	0850	5KV	1000	●
900mA	0900	5KV	1000	●
1.00A	1100	5KV	1000	○
1.25A	1125	5KV	1000	○



SELLI

WWW.SELLIFUSE.COM